

ION IRRADIATION INDUCED CRYSTALLIZATION IN AMORPHOUS SELENIUM FILMS

I. Ivan^{*}, S. Kokenyesi^s, A. Csik

Institute of Nuclear Research of the Hungarian Academy of Sciences, Bem tér 18/c, 4026 Debrecen, Hungary

^aDepartment of Experimental Physics, University of Debrecen, Bem tér 18/a, 4026 Debrecen, Hungary

The effect of laser and ion irradiation with 180 keV deuterium ions on freshly deposited and aged amorphous selenium films has been studied by optical transmission and x-ray diffraction measurements. The ion irradiation was found to cause amorphous-amorphous structural transformations and enhancement of the crystallization rate, similarly to He-Ne laser irradiation.

(Received September 12, 2007; accepted September 26, 2007)

Keywords: Amorphous selenium, Ion induced crystallization, Photocrystallization, Photodarkening

1. Introduction

Amorphous and glassy chalcogenides exhibit various structural changes under the action of light of photon energy comparable with their band gap [1]. These structural transformations cause changes in optical, electrical and other physical and chemical properties, which can be utilized in optical recording, fabrication of passive optoelectronic elements and other technological fields [1-5]. Thanks to it these phenomena have attracted significant attention from both the fundamental and applied science during the last three decades and by now their nature has been revealed experimentally rather well, though the mechanism is still a matter of debates [6].

Similar effects can also be induced by high energy ionizing irradiation (γ -photons, electrons, ions) [7-12]. For instance, recently it was demonstrated that in As_2S_3 and AsSe thin films irradiation with 40-180 keV H^+ and D^+ ions produces structural and optical changes very similar to those induced by visible light [11,12]. There is far less information about the high energy irradiation induced effects than about those induced by band gap light. Further experimental work is needed to reveal this group of phenomena. This paper is devoted to the experimental study of the effect of ion irradiation induced structural transformations in amorphous selenium thin films by means of optical and x-ray diffraction measurements.

2. Experimental

The samples used in this study were 1 μm thick amorphous selenium thin films prepared by vacuum thermal evaporation of 99.999 % pure elemental selenium onto borosilicate glass substrates (Corning No 7059). The substrates were held at room temperature during the deposition. The pressure of residual gases in the deposition chamber was 2×10^{-5} mbar. The film thickness was determined from the interference fringes of the optical transmission spectra.

* Corresponding author: ivani@atomki.hu

The samples were divided into two groups. The samples A were irradiated and examined in two days after preparation, while samples B were subjected to the same investigations after one month of room temperature storage in dark.

The irradiations were carried out with a 200 keV linear accelerator at the Institute of Experimental Physics of University of Debrecen with 180 keV D^+ ions with 10^{12} ion/cm²s ion fluence rate. The setup of the irradiation chamber is shown in Fig. 1. The sample was tilted in a 45° angle relative to the ion beam. From the bottom side a low power density He-Ne laser beam (the beam of a 5 mW laser attenuated by a neutral filter) was introduced to the chamber to measure the kinetics of the transmission change of the film during the ion irradiation. For comparison the kinetics of the photo-induced transmission change has also been measured in the same setup. For this the filter was removed and the laser beam fell directly to the sample with 0.3 W/cm² power density.

The x-ray diffraction measurements were carried out with the help of a Siemens diffractometer (Cu anode, θ -2 θ geometry).

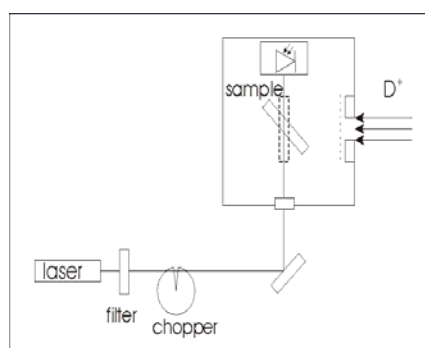

Fig. 1. The scheme of the experimental setup used for the optical measurements.

3. Results and discussion

In Fig. 2 is shown the transmission modification of the samples during the ion irradiation versus the ion fluence. In the Fig. 3 the kinetics of the photo-induced transmission change are shown for comparison. To help the comparison, the energy absorbed by the films is represented on the upper horizontal axis in both figures. One can see at once that the character of the transmission change caused by ion and laser irradiations are quite similar, and essentially agrees with that reported in [13].

The darkening has two components – a faster and a slower. The faster one saturates at about 20 J/cm² exposure and causes about 10-15 % decrease in transmission. This corresponds to photo-induced structural transformation within the amorphous phase. Since the glass transition temperature of selenium is close to the room temperature ($T_g \sim 314$ K), this change is not stable. If the irradiation is interrupted at this stage, the self-annealing rapidly restores the transmittance to its initial value. This is followed by a slower darkening, during which the transmission can decrease down to 5-10 % of its initial value. This slower darkening corresponds to crystallization of the film. Clear evidence for the crystallization can be seen in the x-ray diffraction spectra taken before and after the irradiations (see Fig. 4). In the freshly prepared samples the two components can be well separated, the crystallization is relatively slow and preceded by a nucleation period. (In ion irradiated samples A only the very beginning of this slower darkening was observed in physically reasonable irradiation time). In contrast, in samples B the two processes are hard to separate, the crystallization starts together with the darkening related with the amorphous-amorphous structural transformations. This is because in samples B the nucleation has already taken place during the one month storage and after that the crystal growth during the irradiation can be rather fast. The x-ray diffraction proves that the samples B were not perfectly amorphous before the irradiation, as small diffuse peak was observed at 23.5°.

The x-ray diffraction spectra supply us with some more information. First of all, the crystalline phase can be identified as hexagonal selenium. The fact that in the spectra of the laser and ion irradiated samples only the 100 peak at 23.5° is observed means that the Se chains orientate parallel to the film surface, which is typical for the laser crystallized Se films [14,15]. The spectrum of the control sample annealed at 200°C contains also the 101 (29.7°) and higher order peaks, though the relative intensity of the 100 peak is still higher than in the spectrum of the powder sample.

It is interesting that the ion irradiation apparently enhances the crystal growth more efficiently than the laser irradiation – for laser irradiation about an order of magnitude much absorbed energy is needed than for the ion irradiation to reach the same crystal fraction. This may be because the ions energy is absorbed with the same efficiency in the amorphous and crystalline parts, while the light is absorbed much more effectively in the crystalline parts.

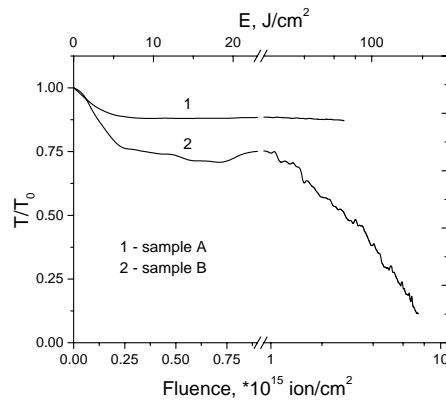

Fig. 2. The relative transmission change of Se films during D^+ -irradiation.

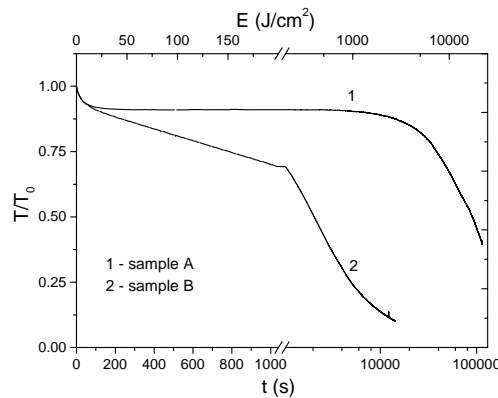

Fig. 3. The relative transmission change of Se films during laser irradiation.

The above presented results demonstrate that the effect of ion irradiation with medium energy light ions causes similar optical and structural changes in amorphous selenium films as does the irradiation with band gap light. Particularly, at lower fluences ($\sim 2 \times 10^{14}$ ions/ cm^2) reversible structural transformations within the amorphous phase are observed, while at larger fluences crystallization takes place. Regarding to the structural transformations within the amorphous phase it is in good agreement with our previous observations of the similarity of effect of light and ion irradiation on the structure and optical properties of As_2S_3 and AsSe films [11,12]. Having in mind the recently observed the similarity of the effect of light and ion irradiation on the interdiffusion in $\text{Se}/\text{As}_2\text{S}_3$ and $\text{As}_{0.2}\text{Se}_{0.8}/\text{As}_{0.2}\text{S}_{0.8}$ multilayers [16], the common ability of the light and ion irradiation to enhance the crystallization rate of selenium suggests that this similarity is not

limited to the amorphous-amorphous structural transformations, but has more general validity. Probably within certain limits it is not really important how the local structure becomes excited. After it becomes excited the atoms start moving in a way predetermined by the structure itself.

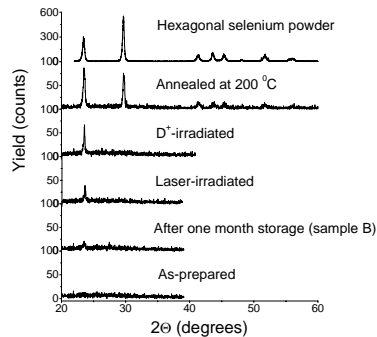

Fig. 4. The x-ray diffraction spectra of variously treated samples.

4. Summary

Laser and ion irradiation induced amorphous-amorphous structural changes and crystallization have been observed in amorphous selenium films. According to the comparative optical transmission measurements the light and ion induced changes are similar, though the light enhances the crystallization rate less efficiently than the ion irradiation because of the high absorption of the crystalline phase. The stimulated crystallization rate is strongly influenced by the ageing of the Se film.

Acknowledgements

This work was supported by OTKA grant K67685.

References

- [1] M. Popescu, *J. Optoelectron. Adv. Mater.* **7**, 2189 (2005).
- [2] J. Teteris, *Current Opinion in Solid State and Material Science* **7**, 127(2003).
- [3] V. Palyok, I. A. Szabó, D. L. Beke, A. Kikineshi, *Appl. Phys. A* **74**, 683 (2002).
- [4] D. Savastru, S. Miclos, R. Savastru, *J. Optoelectron. Adv. Mater.* **8** (2006) 1165.
- [5] J. Viens, C. Meneghini, A. Villeneuve, T. V. Galstian, É. Knystautas, M. A. Dugay, K. A. Richardson, T. Cardinal, *J. Lightwave Technol.* **17**, 1184 (1999).
- [6] G. Pfeiffer, M. A. Paesler, S. C. Agarwal, *J. Non-Cryst. Solids* **130** (1991)111.
- [7] V. O. Balitska, O. I. Shpotyuk, *J. Non-Cryst. Solids* **227-230**, 723(1998).
- [8] S. S. Sarseminov, E. E. Abdulgafarov, M. A. Tumanov, N. A. Rogachev, *J. Non-Cryst. Solids* **35-36** (1980) 877.
- [9] K. Tanaka, *Appl. Phys.Lett.* **70**, 260 (1997).
- [10] P. K. Dwiedi, S. K. Tripathy, A. Pradhan, V. N. Kulkarni, S. C. Agarval, *J. Non-Cryst. Solids* **266-269**, 924 (2000).
- [11] I. Ivan, M. Veres, I. Pócsik, S. Kokenyesi, *Phys. Status Solidi A* **201**, 3193 (2004).
- [12] I. Ivan, S. Szegedi, L. Daroczi, I. A. Szabo, S. Kokenyesi, *Nucl. Instrum. Meth. B* **229**, 240 (2005).
- [13] V. I. Mikla, I. P. Mikhalko, *J. Non-Cryst. Solids* **180**, 236 (1995).
- [14] T. Inami, S. Adachi, *Phys. Rev. B* **60**, 8284 (1999).
- [15] K. Ishida, K. Tanaka, *Phys. Rev. B* **56**, 206 (1997).
- [16] I. Ivan, D. L. Beke, S. Kokenyesi, I. A. Szabo, A. Csik, , *J. Optoelectron. Adv. Mater.* **7**, 1831 (2005).